

Silicone Surfactants

Synthesis

Overview

- General Structure of SPE's
 - Linear Pendant
 - Branched Terminal
- Synthesis
 - Silicone
 - Müller-Rochow Process
 - Hydrolysis
 - Equilibration
 - Polyether
 - OH terminated
 - Methyl capped
 - Acetate capped
 - Coupling
 - Hydrosilation
 - Transesterification

Silicone Surfactant Linear Pendant

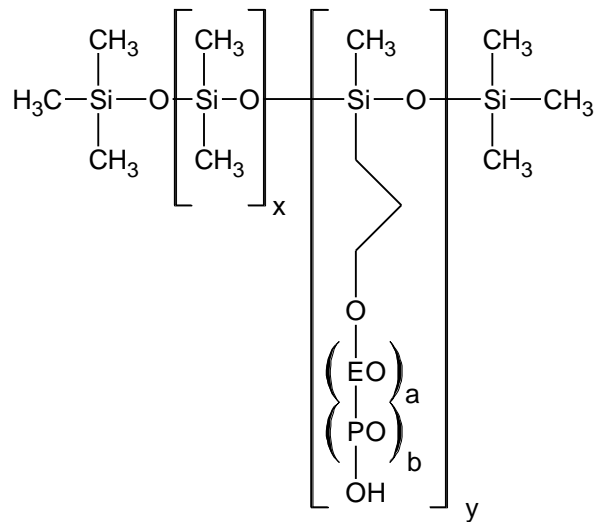

Silicone Surfactant Branched Terminal

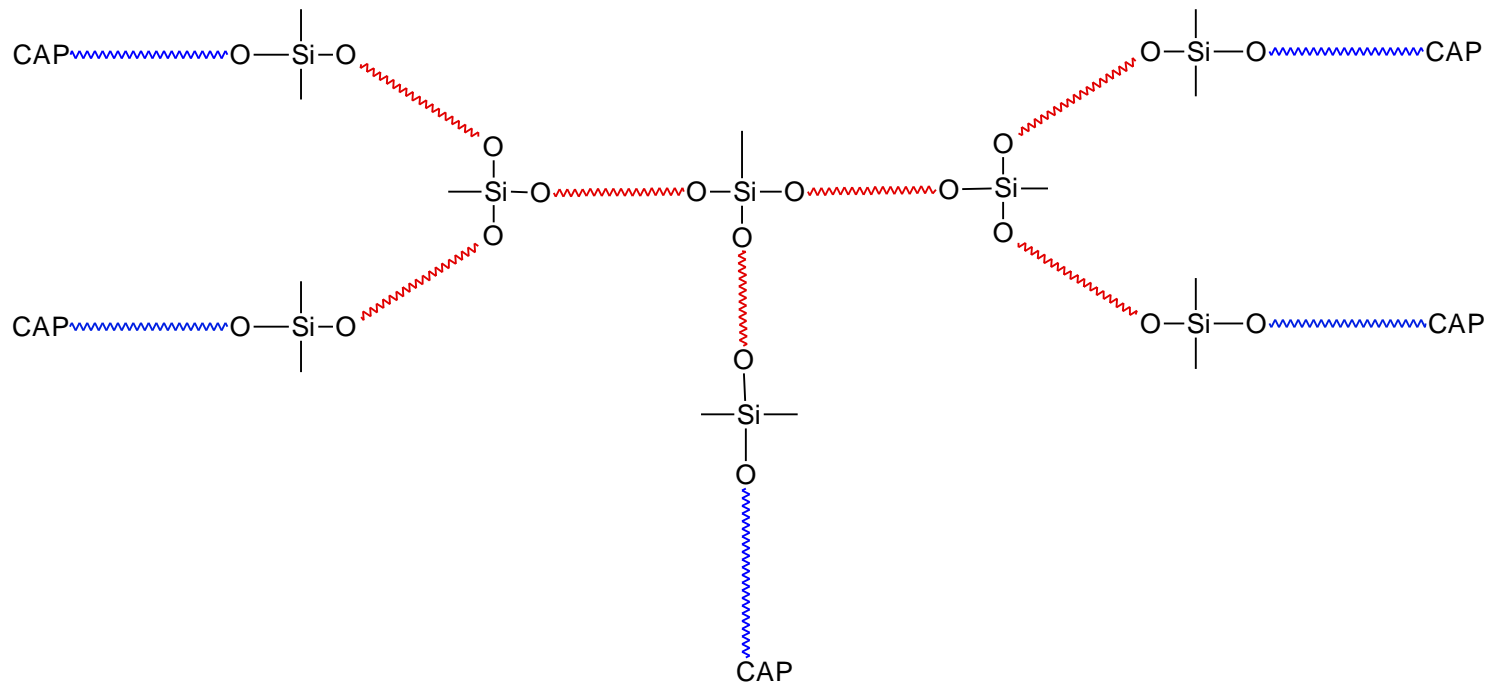

Müller-Rochow Process

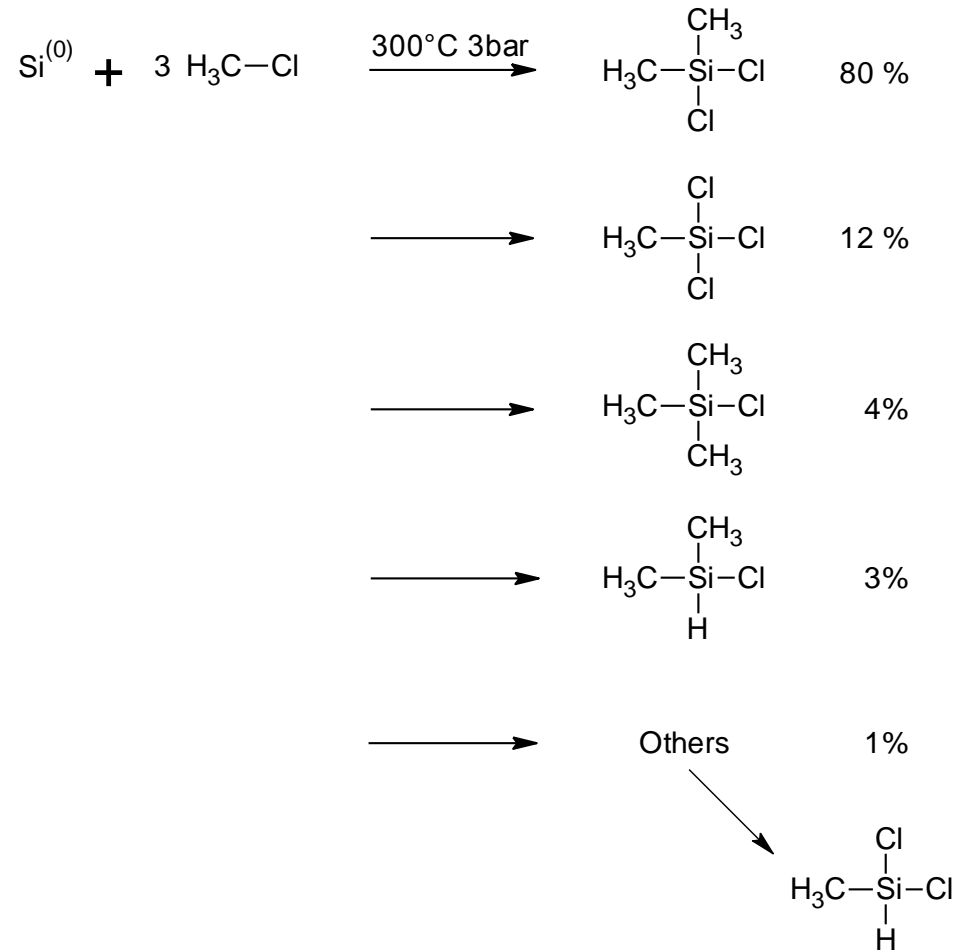

Si-H Fluid Hydrolysis

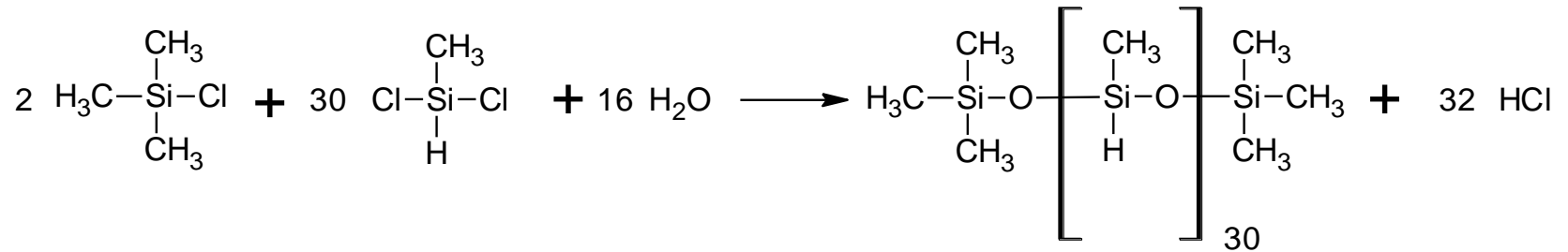

75-77-4

75-54-7

MM Synthesis

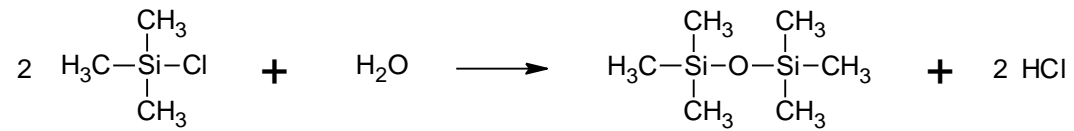

75-78-5

107-46-0

Equilibration I

D4

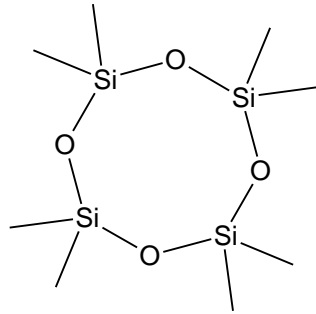

+

Si-H Fluid

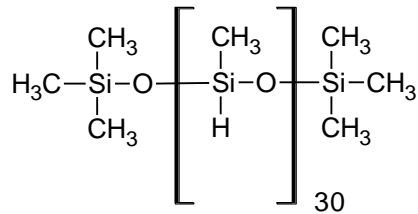

+

MM

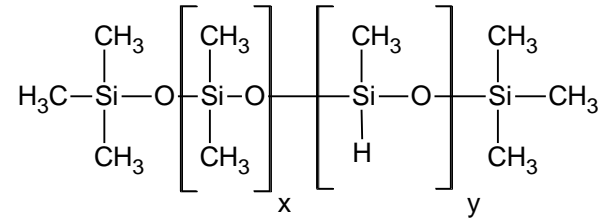
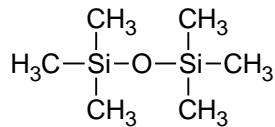

Linear Backbone

Equilibration II

2031-67-6

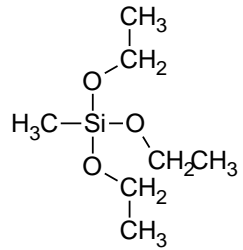

+

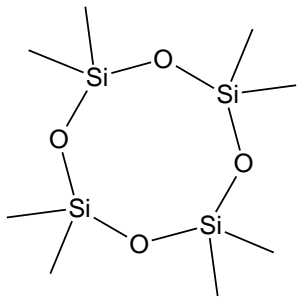

556-67-2

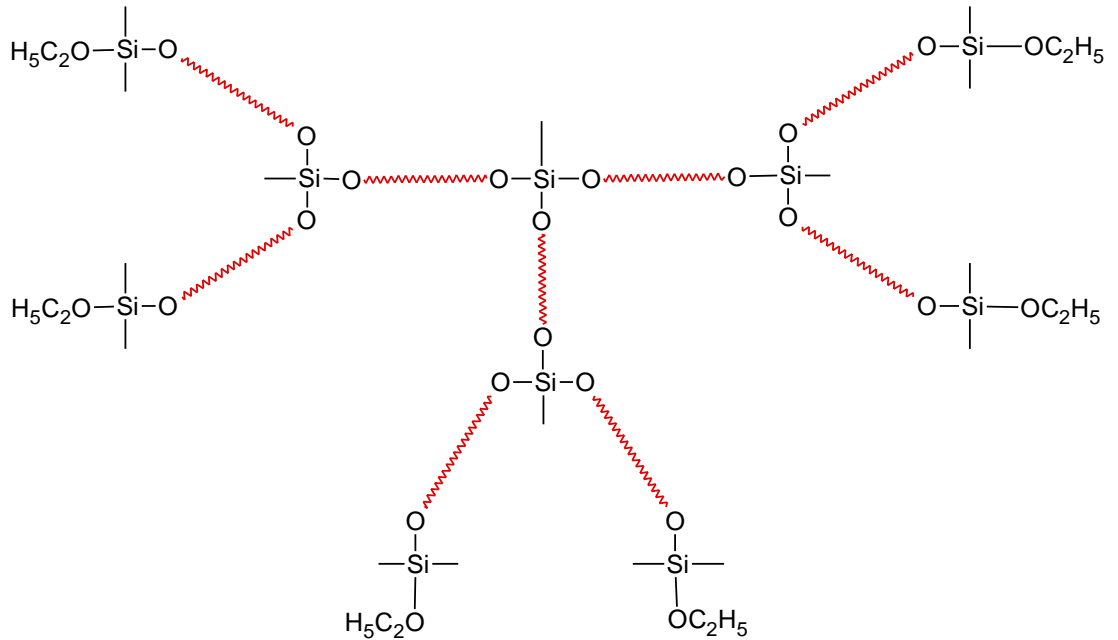
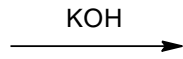

Branched Backbone

Polyether Synthesis OH Terminated

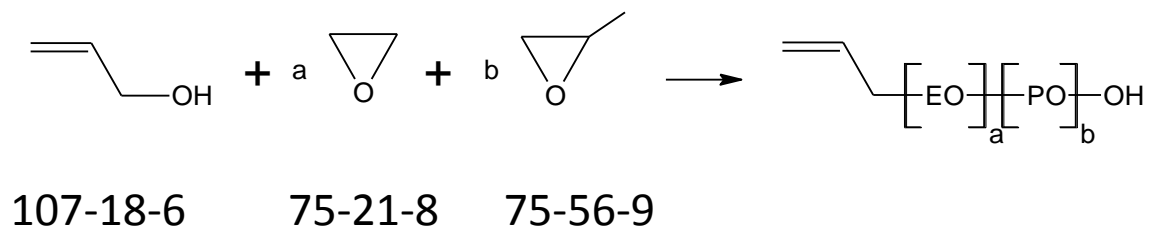

Polyether Synthesis

Methyl capped

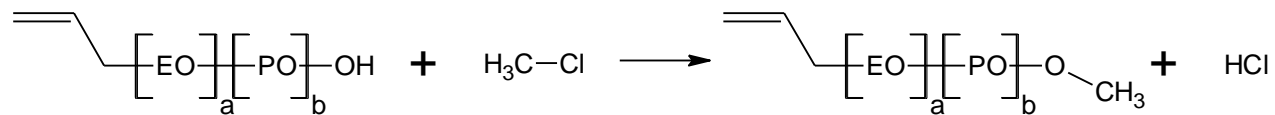

74-87-3

Polyether Synthesis

Acetate capped

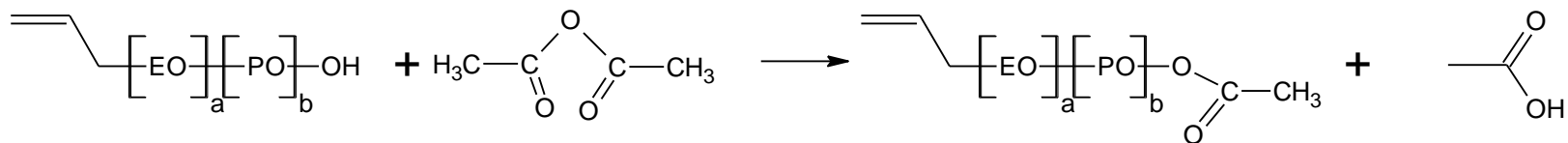

108-24-7

Hydrosilation

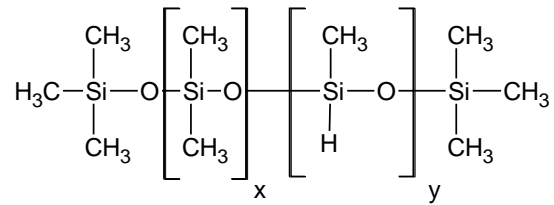

+

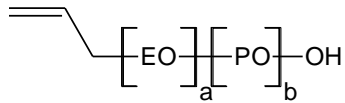

and/or

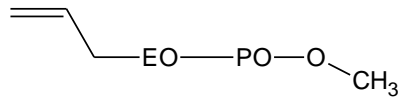

and/or

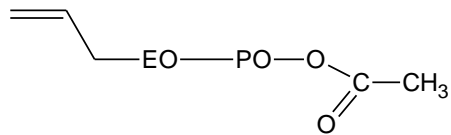

Pt Catalysts

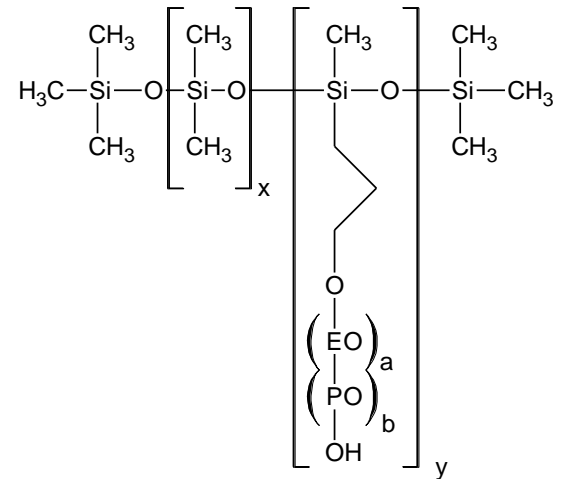

Transestrification

